

emcogroup

Designed for your profit

[That's
E[M]CONOMY:]



Big Performance for small Parts. EMCO MAXXTURN 25

Universal turning center for the complete machining
of small, precision parts

EMCO MAXXTURN 25

[Work area]

- Spacious
- Free chip flow
- Easy access

[Machine design]

- Compact
- Requiring minimal floor space

[Hydraulic]

- Front-operated

[Coolant reservoir]

- Large coolant container
- Mounted on wheels
- Easy to clean
- Highest thermostability



Photo shows machine with options

The EMCO MAXXTURN 25. The perfect solution for the complete machining of small parts. Compact, economical and high precision. Suitable for bar parts up to a diameter of 25 mm and chucked parts up to \varnothing 85 mm. Fitted with a counter spindle, Y axis and driven tools – or without if you prefer. The tool turret has space for 12 VDI16 tool holders. The 36 indexing positions mean the number of tools can be increased to 42 cutting edges. The MAXXTURN 25 comes with a Siemens or Fanuc control including ShopTurn or ManualGuide conversational programming system.

[Workpieces]

[Control]

- Ergonomically placed
- Siemens or Fanuc
- LCD color monitor
- Optional teleservice, Ethernet connection and PC keyboard

[Shelf]

- Retractable
- Enough space for gauges and operating tools

[Machine cover]

- Total protection from chips
- 100% coolant retention
- Large safety-glass window in door
- Clear view into the workspace
- Built-in buttons for operator convenience



Tooth implant
(Titanium)



Flange
(Aluminium)



Shaft
(Stainless steel)

[Technical]

Highlights

- Large speed range
- Counter spindle for complete machining
- Driven tool positions
- Stable Y axis
- High rapid-motion speeds
- Best machining quality
- Compact machine construction
- Made in the Heart of Europe



Main spindle. Being mounted on pre-stressed high-precision bearings, the main spindle can reach speeds ranging from 0–8000 rpm, making the production of small parts extremely economical and exact. The MAXXTURN 25 has a hydraulically operated hollow clamping cylinder with 25.4 mm bar clearance as standard equipment. A C axis with holding brake is also a standard fitting for milling operations. Resolution: 0.001°.



Tool turret. Fast, servo turret with 12 VDI 16 position holes. It can be indexed up to 36 positions to increase the number of tools. This means up to 42 tools can be integrated when using multi-tool holders. The swivelling can be slowed or even stopped to simplify running-in the machine.



Counter spindle. The machine has an extremely compact counter spindle for machining the reverse side. Mounted on guide rails, it can be positioned at 30 m/min. The parts are taken from the main spindle and completed in one process. Speeds ranging from 0–8000 rpm mean the best possible prerequisites for turning and drilling. The counter spindle can also be positioned for light milling and drilling operations.

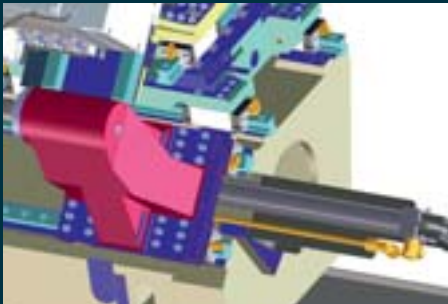

Tailstock. The MAXXTURN 25 MY is also available in a tailstock version. The tailstock is set up on the linear roller slide and can be automatically positioned within a range of 360 mm. The live centre is integrated into the body of the tailstock and ensures a maximum of precision and stability. It is controlled using M functions.



Y axis. The Y axis is integrated into the basic machine structure and stands at 45° to the X axis. Extremely short projections form the basis for solid turning and drilling operations, as well as milling operations without interference contour.

Versions EMCO MAXXTURN 25

MT 25 MY with tailstock, Y and C axes and driven tools

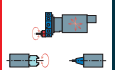

MT 25 SM with counter spindle, C axis and driven tools

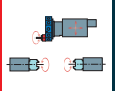

MT 25 SMY with counter spindle, Y axis, C axis and driven tools

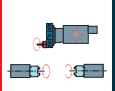

Power

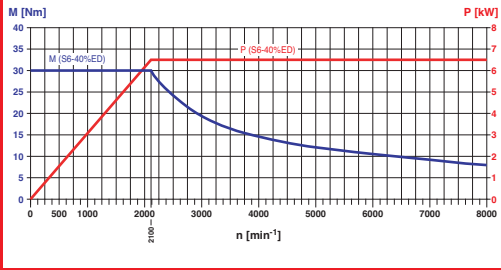

Motor characteristics for the main spindle

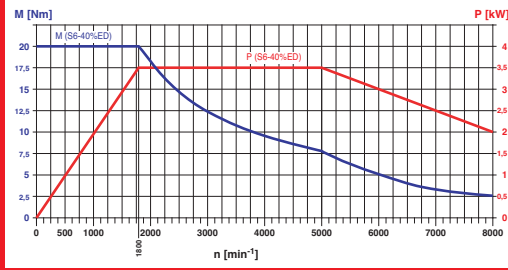

Motor characteristics for the counter spindle

[Main spindle]

- High drive performance
- Compact, thermostable construction
- Large range of speeds (0–8000 rpm)
- Spindle nose $\varnothing 70$ h5
- Bar capacity diameter 25.4 mm
- C axis (0.001° resolution)
- Including spindle brake for milling

[Linear guide ways]

- Pre-stressed in all linear axis
- Free of play in all force directions
- High rapid-motion speeds
- No wear
- Minimal lubrication

[Tool turret]

- 12 position VDI 16 turret disc
- 6 driven tool stations
- 36 position indexing (10° separation)
- Swivel speed adjustable with override

[Counter spindle]

- Space-saving integrated
- Large range of speeds (0–8000 rpm)
- Parts ejector flooded with coolant
- C axis (0.001° resolution)
- Spindle nose $\varnothing 70$ h5

[Machine bed]

- Rigid cast iron body
- Torsion-proof due to heavily ribbing
- Tension-free and thermally separated bolted to the machine stand at 3 points

[Machine base]

- Compact welded-steel construction
- Large coolant tank easy to clean
- No levelling needed
- 100% sealed against coolant leaks

Work area with counter spindle

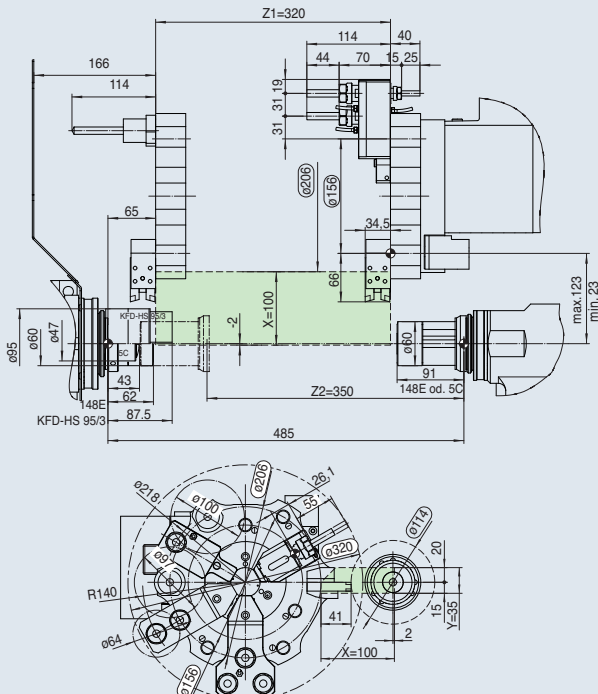

Work area with tailstock

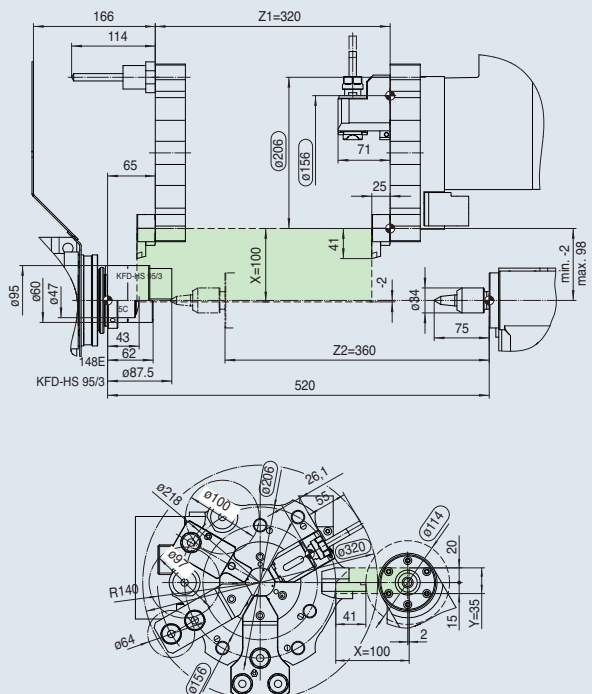

Individual automation with the EMCO bar loaders

The MAXXTURN 25 has two bar-loading systems for economical manufacturing. One is the compact short-bar loader EMCO LM800, and the other one is the EMCO TOP LOAD for 3-meter bars. Both systems can load bars into the machine fully automatically, supporting almost unmanned operation.



[TOOL HOLDERS]



Double face and O.D. turning holder M4-VDI16 (S2Z 810)



Double face and O.D. turning holder M4-VDI16 (S2Z 820)



Quintuple axial tool holder VDI16/ER16 (S2Z 430)



Angular milling holder 90° VDI16 (S2Z 440)



Offset axial milling holder VDI16 (S2Z 420)



Triple axial milling holder VDI16 (S2Z 410)

Machine layout

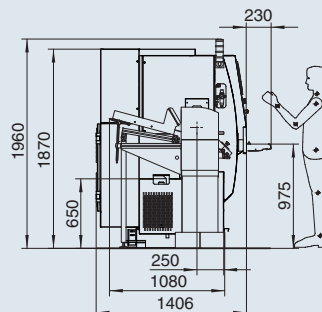
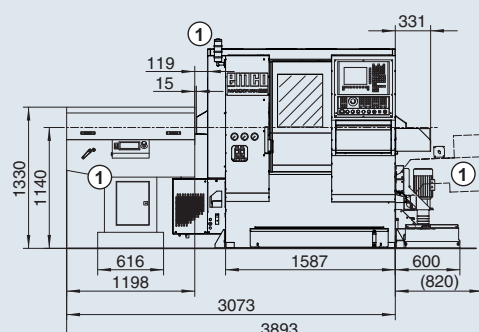

① Option

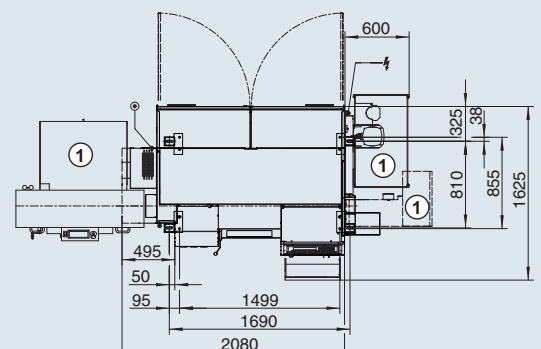

[EMCO TOP LOAD 4-25]

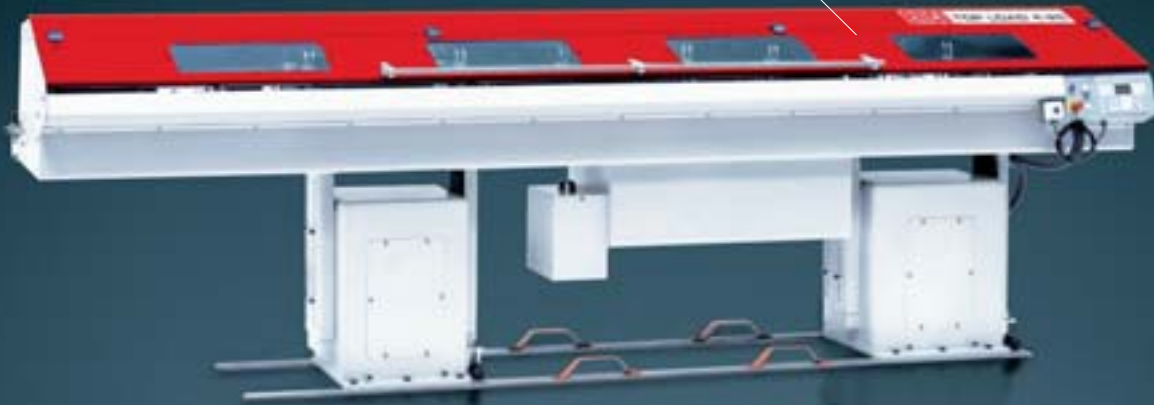

Short and to the point

In view of the ever-increasing pressure on floorspace for machines, EMCO has developed the most compact short loader on the market: the EMCO LM800.



Part catcher

Finished parts are transported from the counter spindle to the finished parts container with the aid of the part catcher. This proven EMCO concept with the swiveling catcher ensures optimum access to the working area, free chip flow and careful removal of the finished parts.



Finished part conveyor

The finished-part pick-up device puts the parts on an accumulating conveyor. A discontinuous belt ensures that the often very complex parts do not fall onto each other.

X	aktuel	4.111.120%	4.100000%	4.101.121%	Bruch Verschl:
	Intezer	219.990.99%	4.100000%	18.140.511%	min. 50%
	geleert	3.250	3.500	3.800	max. 50%
Z	aktuel	4.101.121%	1.100.100%	4.101.100%	Bruch Verschl:
	Intezer	219.990.99%	4.100.100%	4.101.100%	min. 50%
	geleert	3.250	3.500	3.800	max. 50%
Y	aktuel	4.101.100%	1.100.100%	4.101.100%	Bruch Verschl:
	Intezer	219.990.99%	4.100.100%	4.101.100%	min. 50%
	geleert	3.250	3.500	3.800	max. 50%
C	aktuel	4.101.100%	1.100.100%	4.101.100%	Bruch Verschl:
	Intezer	219.990.99%	4.100.100%	4.101.100%	min. 50%
	geleert	3.250	3.500	3.800	max. 50%

EMCO tool break monitoring

The tool status is monitored by evaluating the load on the various axis drive motors. Excessive loads point to wear or broken tools. Too little load means a tool is missing.

[Technical data]

emco group

Designed for your profit

EMCO MAXXTURN 25

Work area	
Swing over bed	325 mm (12.8")
Swing over cross slide	150 mm (5.9")
Main spindle / counter spindle distance	485 mm (19")
Maximum turning diameter	114 mm (4.5")
Maximum part length	315 mm (12.4")
Maximum bar diameter	25.4 mm (1")
Travel	
Travel in X	100 mm (3.9")
Travel in Z	320 mm (12.6")
Travel in Y	+20/-15 mm (0.78"/-0.59")
Travel in Z2	350 mm (13.8")
Main spindle	
Speed range	0 – 8000 rpm
Torque at spindle	30 Nm (22.1ft/lbs)
Spindle nose	ø 70 h5
Spindle bearing	60 mm (2.36")
Spindle bore hole	33 mm (1.3")
Counter spindle	
Speed range	0 – 8000 rpm
Torque at spindle	20 Nm (14.7 ft/lbs)
Spindle nose	ø 70 h5
Spindle bearing	45 mm (1.77")
C axis	
Resolution	0.001°
Rapid motion speed	1000 rpm
Spindle indexing	0.01°
Drive power	
Main spindle	6.5 kW (8.7 hp)
Counter spindle	3.5 kW (4.7 hp)
Tool turret	
Number of tool positions	12
Number of indexing positions	36
VDI shaft (DIN 69880)	VDI16
Tool cross-section for square tools	12 x 12 mm (0.47" x 0.47")

Tool turret	
Shaft diameter for boring bars	16 mm (0.63")
Turret indexing time	0.2 sec
Driven tools	
Speed range	0 – 6000 rpm
Maximum torque	4 Nm (2.9 ft/lbs)
Maximum drive power	1.2 kW (1.6 hp)
Number of driven tools	6
Feed drives	
Rapid motion speed X / Y / Z	20 / 10 / 30 m/min (787 / 394 / 1181 ipm)
Feed force in the X / Y / Z axis	3000 / 4000 / 4000 N (674 / 900 / 900 lbs)
Positioning scatter VDI 3441 in X / Y / Z	3.5 / 3 / 4 (0.00014/0.00012/0.00014")
Coolant system	
Tank volume	140 Liter (37 gal)
Pump power standard	0.57 kW (2.2 hp)
Pump capacity at 3,5bar / 1bar	15 / 65 l/min (4 / 17.2 gal/min)
Pump capacity at 14 bar / 6 bar (optional)	10 / 60 l/min (2.6 / 15.8 gal/min)
Power consumption	
Connected load	12 kVA
Compressed air	6 bar (87 PSI)
Dimensions and weight	
Height of spindle center above floor	1140 mm (45")
Total machine height	1870 mm (73.6")
Foot print (without chip conveyor) LxD	2180 x 1425 mm (85.8" x 56.1")
Total weight	2100 kg (4630 lb)
Safety devices	
	CE conform



EN4580 - 04/14 - Subject to change due technical progress. Errors and omissions excepted.

www.emco-world.com