

emco group

Designed for your profit



EMCOMAT E-200 MC

**Universal lathe
with cycle-control**

TURNING
EMCO-WORLD.COM

EMCOMAT E-200 MC for the manual or cycle-controlled machining of large workpieces

The EMCOMAT E-200 MC is intended for production-oriented users. High chip-cutting power, precision and universality are its characteristic features. The generous workspace allows large workpieces to be machined. The EMCOMAT E-200 MC's circulating ball screws free of play allow precise axes positioning. The machine can be operated manually with hand wheels or feed keys or, with Sinumerik 828D as cycle-controlled lathe. Therefore, it's applicable for the production of single parts or small series. The 'manual machine' function on the user interface of the SINUMERIK 828D optimally implements the concept of a controlled conventional lathe. Whether during set-up, programming or machining – the skilled workers' normal view of the work process is improved. EMCO's wide range of options covers everything you need to handle even the most complicated machining projects.

1 HEADSTOCK

- Solid cast-iron construction
- Powerful Siemens drive system
- Short taper spindle nose with CAMLOCK adaptor
- Spindle bore diameter \varnothing 53 (50) mm

2 CONTROL

- Sinumerik 828D
- Easy programming
- 10,4" LCD monitor
- USB interface

3 MACHINE BASE

- Most rigid welded steel construction
- Channel for easy fork lift transportation
- Integrated chip tray
- 2 drawers for tool storage
- Filled with special granulate sand for dampening

4 CONTROL PANEL

- Ergonomically placed by sliding control panel
- Easy and flexible handling

5 MACHINE BED

- Diagonally ribbed
- Induction hardened
- Hardened linear guides
- Tension-free three point integration

6 TOOL HOLDER

- Various manual tool system

7 TAILSTOCK

- Made from high-quality, vibrationdamping gray cast iron
- Sits on linear guides



- High cutting power
- High quality casting with strong ribs for low-vibration machining operations
- Fully automatic central lubrication of the X and Z slides and the recirculation ball spindles
- Electronic handwheels are available for manual operation of X and Z axis
- Made in the Heart of Europe

Engineering

Sinumerik 828D.

SINUMERIK 828D: High performance CNC control for ultimate accuracy and machining speed. SINUMERIK 828D and SINAMICS drive and motors are perfectly tailored for state of the art turning machines. Powerful CNC-functions enable highest work-piece accuracy at a minimum of machining time. With a flexible CNC programming language and the state of the art ShopTurn machining step programming, parts can be programmed and machined with maximum effectiveness. The 'manual machine' with handwheels or feed buttons provides you with machining capabilities as for a cycle turning machine. All important machining actions can be performed without an associated part program needing to be created.

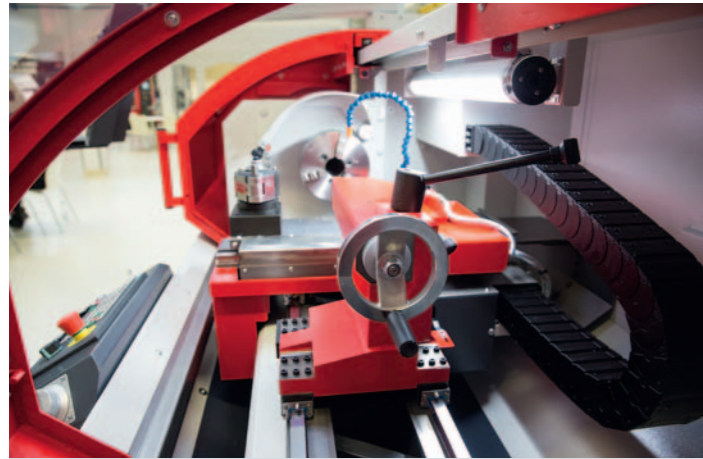

Work area. During machining in automatic mode the work area is closed by two slideable chip protection doors. When using the manual mode machining with opened doors is possible.



Optional equipment: EMCOMAT E-200 MC can be fitted with various chucks and tool holder systems.

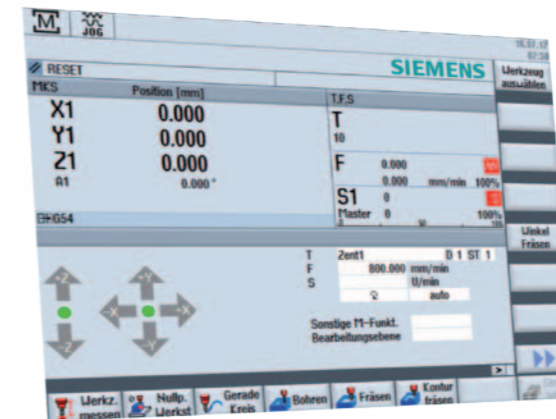

- Digital drive interface, Safety Integrated
- User interface „Manual Machine“
- Manual mode (Digital Readout)
- Integrated DXF Reader (Option)
- Measuring/set workshift (edge, corner, pocket/drill, journal, plane)
- Single cycle processing without part program
- Easy workpiece processing: Axis movement, Angel milling, straight line, circle



Linear guides. Soid and hardened linear guides in both axis.

Options

- Quick-change tool holder systems
- Tapered rod chuck
- Collet chuck
- Steady rests
- Plane spiral chucks
- And much more

Standard machine equipment

- Hardened linear guides in X and Z axis
- Recirculating ball spindles for X and Z axis
- Sinumerik 828D with „manual machine“ and and 10,4" LCD monitor
- Coolant system
- Central lubrication of guides and recirculating ball spindles
- Electronic handwheels for X and Z control
- Machine lighting
- Partly covered workspace with sliding chip-stop doors
- Loading drawers
- Operator tools
- User guide and spare parts list
- Documentation of the electrical systems

The following functions are available:

- Measure tool
- Traverse axes
- Set zero offset (ZO)
- Turn straight line / circle
- Drill, such as centered drilling, centering, deep-hole drilling
- Turn, such as stock removal, grooving, thread cutting
- Turn contour



User-friendly input screens with help screens and animated elements are available for parameterizing the cycles. For the manual workpiece machining, the axes and spindles are controlled using the following options:

- Control of the cross slides using Handwheels of the X- and Z-axis, or Axis direction switches.
- Spindle control using Spindle rotation direction switches.



Connecting sleeve
(Steel)



Drive shaft
(Steel)

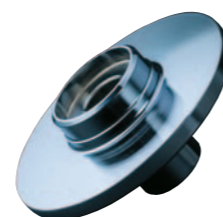

Flange
(Steel)

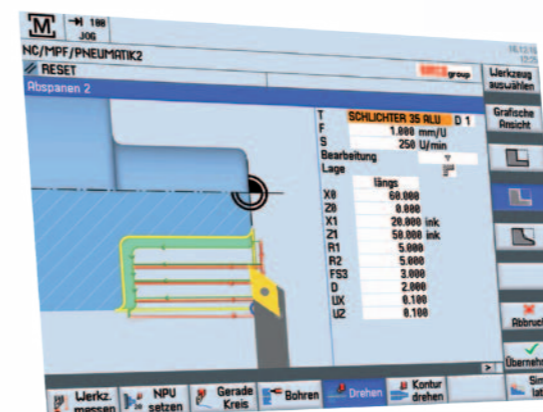

Machine layout

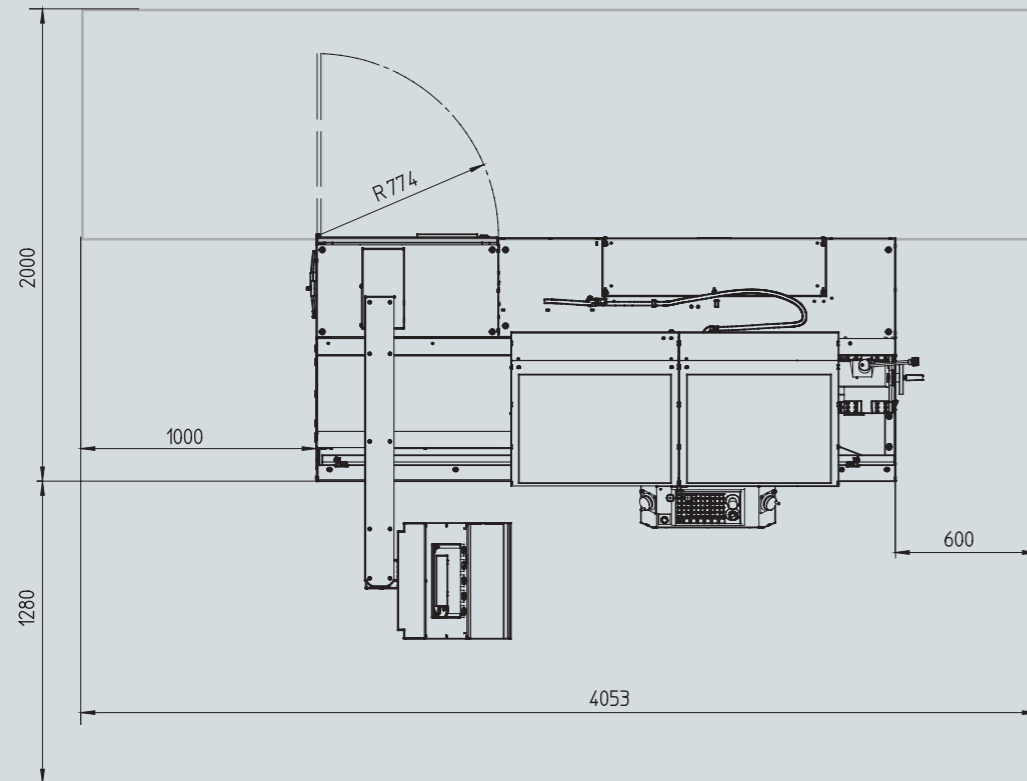
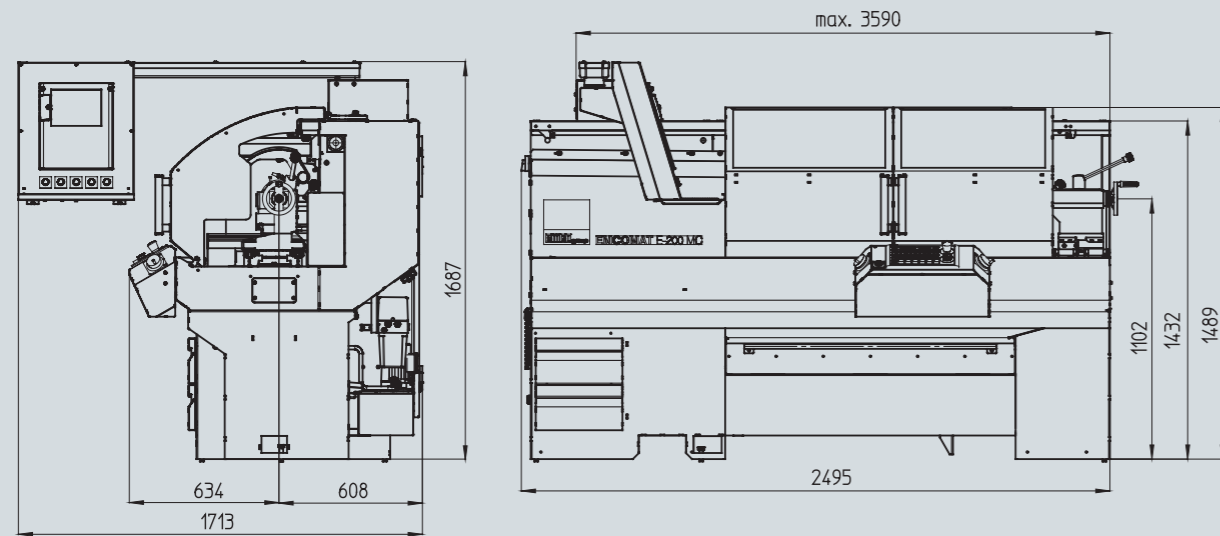

Specifications in millimeters

Technical data

Work area

Distance between centers	1000 mm (39.37")
Center height	200 mm (7.87")
Swing over bed	Ø 400 mm (15.74")
Swing over cross slide	Ø 220 mm (8.66")
Travel longitudinal	900 mm (35.43")
Travel cross slide	220 mm (8.66")
Cross slide - width	150 mm (5.90")

Main spindle

Spindle bore A2-5/DIN 55029	Ø 53 / 50 mm (2.08 / 1.96")
Spindle diameter	Ø 80 mm (3.14")
Max. chuck diameter	Ø 200 mm (7.87")
Max. face plate diameter	Ø 260 mm (10.23")
Spindle speeds	50 – 4000 rpm
Spindle speed regulation	stepless

Main drive

AC motor	infinitely adjustable
Power at 100% / 40% E.D.	7,5 / 10 kW (9.9 / 13.25 hp)
Max. torque at main spindle	108 Nm

Feed X/Z

Feed range X/Z axis	0 – 8000 mm/min (0 – 314 ipm)
Rapid motion speed X/Z axis	10 m/min (39.37 ipm)
Max. feed force	4 kN

Tailstock

Quill diameter	Ø 50 mm (1.96")
Inner tape quill	MT3
Quill travel	120 mm (4.72")

Allowable workpiece weights

Flying (max 5kg at 4000 r.p.m.)	30 kg (66.13 lb)
With tailstock	80 kg (176.36 lb)

Dimensions

Total length	2495 mm (98.22")
Total width	1730 mm (68.11")
Total height	1700 mm (66.92")
Weight of machine with 1000 mm (39.37") center distance	1500 kg (3307 lb)



EN3508 - 08/18 - Technical modifications reserved. Errors and omissions excepted.