

**EMCO**



**MAXXTURN 95**

**Universal CNC turning center for machining shafts and chuck parts**





# COMPLETE SOLUTIONS – DIVERSE POSSIBILITIES

Maxxturn 95 is suitable for part lengths of up to 1300 mm and a turning diameter of 500 mm and can handle turning and milling operations involving heavy machining as perfectly as machining of precision parts with highest surface quality. A highly accurate C-axis, a rigid Y-axis with large movement path and high rapid traverses complete the performance package.



Wheel  
(Aluminium)

## 1 CONTROL UNIT

- / Ergonomic, swivel-type control panel
- / Sinumerik ONE with 15" color monitor
- / Comprehensive machining cycles
- / 3D simulation
- / USB interface, 230V power socket

## 2 WORK AREA

- / Plenty of open space
- / Perfect chip flow
- / Easily accessible

## 3 MAIN SPINDLE

- / Two versions available:
  - High-torque belt drive
  - Dynamic and rigid direct drive
- / Max. speed range 2500 / 3500 rpm
- / Spindle nose A2-8 (DIN 55026)
- / Partly hollow draw-tube  $\varnothing$  95 x 670 mm
- / Through hole  $\varnothing$ 95 mm optional

## 4 TOOL TURRET

- / 12-position VDI 40
- / 12 additional position on the outside with cooling connection (block-tool)
- / Synchronized tapping and polygonal turning as standard



## 5 Y-AXIS

- / Travel +80 / -60 mm
- / 90° implemented in the machine construction
- / Large distance between guides
- / Stable and compact construction

## 6 CHIP CONVEYOR

- / Hinged type chip conveyor with ejection height of 1150 mm (45.3")
- / 350-liter coolant volume
- / Included in the basic version

## 7 MACHINE COVER

- / All-round protection against chips
- / 100% coolant retention
- / Large safety glass window in door
- / Clear view into the work area

## 8 COMPACT MACHINE BUILD

- / Requires minimal floor space

## 8 OIL MIST SEPARATOR (OPTION)

Machine with optional equipment

# DESIGN

Designed on the basis of FEM analyses, the MAXXTURN 95 meets the high demands of modern machining in an ideal manner. The machine's core element is the one-piece machine bed. It is designed as a closed welded steel construction and filled with HYDROPOL®. Additional reinforcements ensure maximum stability in the more highly stressed areas. This guarantees maximum stiffness, precision and optimum vibration damping. The MAXXTURN 95 stands for high durability teamed with high processing accuracy. It is the basis for production with a high added value.

## 1 TOOL TURRET

- / VDI quick-change system
- / 12 driven tool stations
- / Additional Block-Tool mounting surfaces to hold long boring bars
- / Adjustable swivelling speed

## 2 MAIN SPINDLE

- / High drive performance 42 / 33 kW
- / Large holding torque for milling
- / Closed-circuit cooling system
- / A2-8 spindle nose
- / Partly hollow draw-tube  $\varnothing 95 \times 670$  mm
- / Hollow clamping cylinder  $\varnothing 95$  mm (optional)

## 3 ROLLER GUIDES

- / In all linear axes
- / Preloaded
- / No backlash in any direction of force
- / High rapid-motion speeds
- / No wear
- / Minimal lubrication required

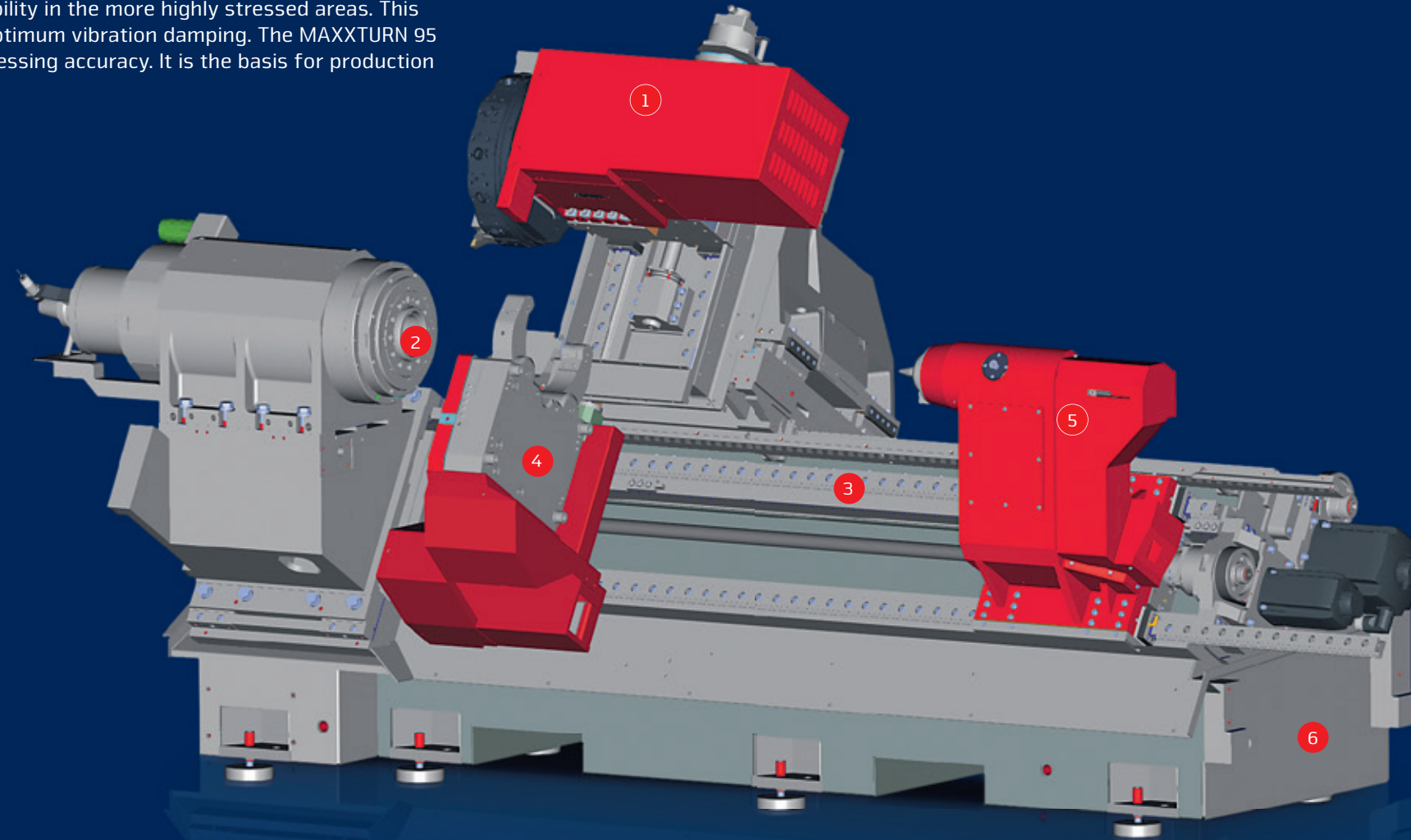

## 4 STEADY REST

- / Clamping range  $\varnothing 30 - 245$  mm
- / Self-centering
- / Centrally lubricated with pressurized sealing air
- / Tag-along positioning or NC controlled

## 5 TAILSTOCK

- / 1050 mm travel range (915 mm with steady-rest)
- /  $\varnothing 100$  mm quill diameter
- / 120 mm quill stroke
- / MT4 inside taper
- / Tag-along positioning or NC controlled

## 6 MACHINE BASE

- / Monoblock construction
- / Welded steel design filled with HYDROPOL®

# Power and Torque

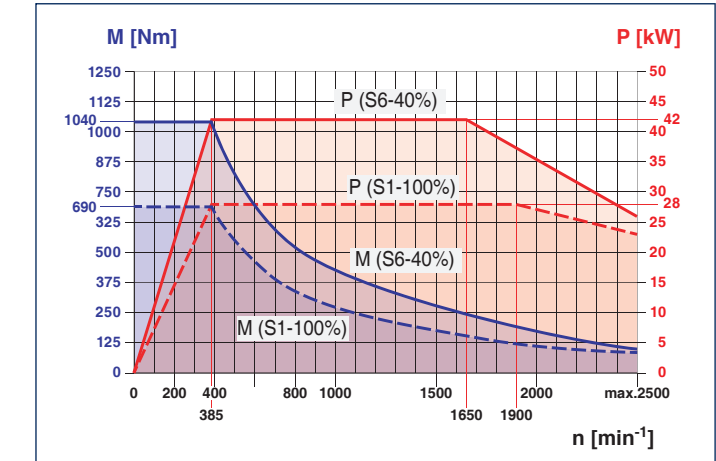

Performance and torque curve for main spindle with belt-drive

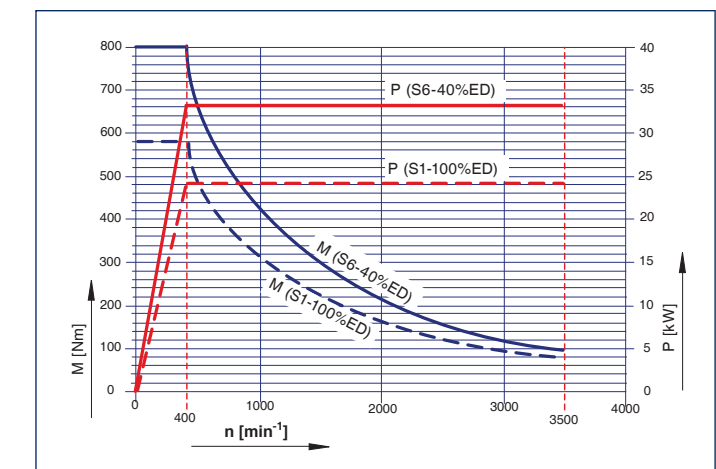

Performance and torque curve for main spindle with direct drive



# TECHNICAL HIGHLIGHTS

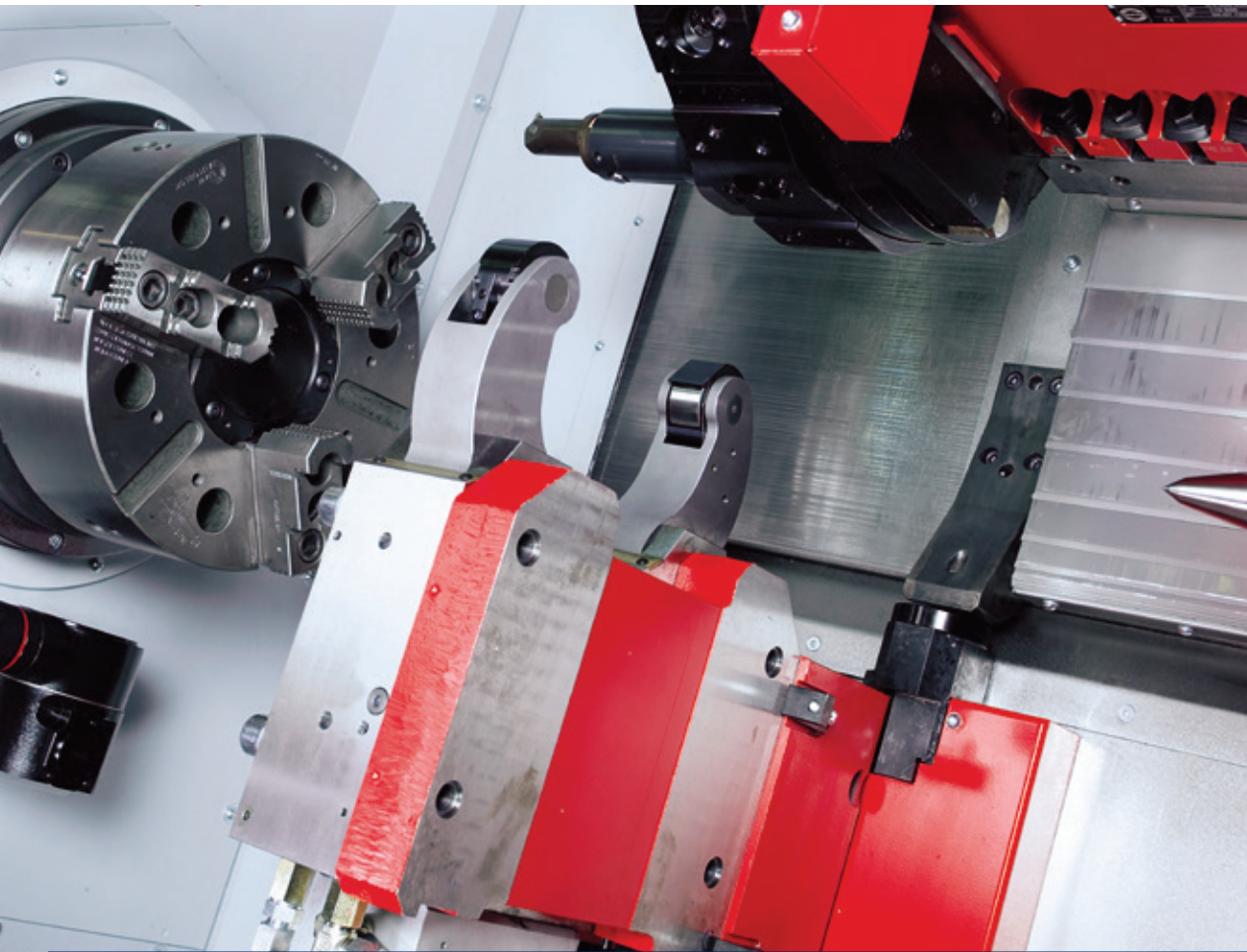

## STEADY-REST

The hydraulic operated self-centering steady-rest has a clamping range of  $\varnothing$  30 – 245 mm. It is mounted on a slide, which can be positioned via the Z-axis-slide or optionally via an additional servo drive using a ball screw. At the determined position the slide is hydraulically clamped. The steady-rest includes chip protection and central oil lubrication.

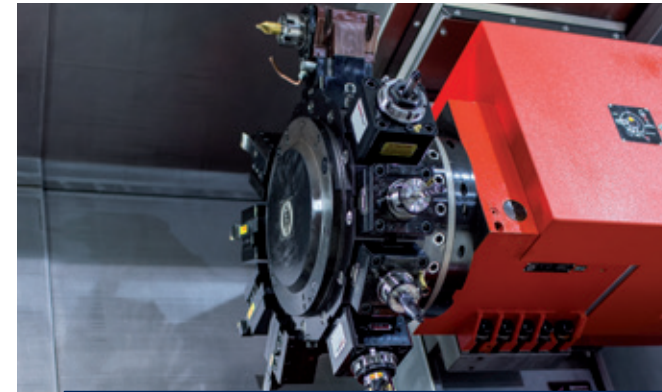

## BMT TURRET

For cost-effective production of complex turning/milling work pieces, in which milling is predominant, the optional BMT 55P turret with water-cooled direct drive is available. With a maximum of 12000 rpm, 30 Nm and 10 kW, this turret offers optimum conditions, stability for complete machining and maximum productivity.



## TAILSTOCK

The tailstock is mounted on linear roller-type slides and can be positioned via the z-axis-slide. Optionally an additional servo drive using a ball screw can be offered. At the determined position the slide is hydraulically clamped. So that a quill with integrated bearings and MT4 cone can support the workpiece. Therefore the quill can move up to 120 mm.

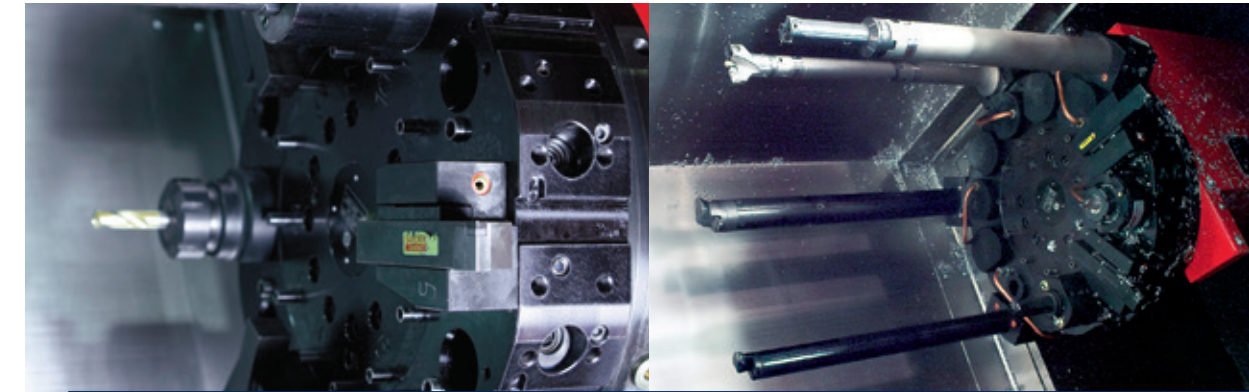

## TOOL TURRET

12 + 12 station hybrid tool turret - VDI40 + block-tool, axial turret with single-motor technology. A servo motor powers the driven tools and the swivel movement. No tool rise, continuous switching with directional logic. Each station can take up driven tool holders with DIN 5480 coupling. 12 additional block-tool interfaces allow the use of large and heavy boring bars up to a diameter of 50 mm.



## MAIN SPINDLE

Two versions are available: One using a conventional beld-drive for high torque (up to 1040 Nm) and heavy machining and another one using the approved water-cooled motor spindle for higher spindle speeds. This one also offers optimal conditions for complex milling operations.

## HIGHLIGHTS

- / Extremely robust construction
- / Top machining precision
- / High rapid motion speed
- / Stable Y-axis with large travel
- / Optional: NC steady rest or tailstock
- / State-of-the-art control technology
- / Driven tools with C-axis
- / Simple, conversational programming
- / Made in the Heart of Europe

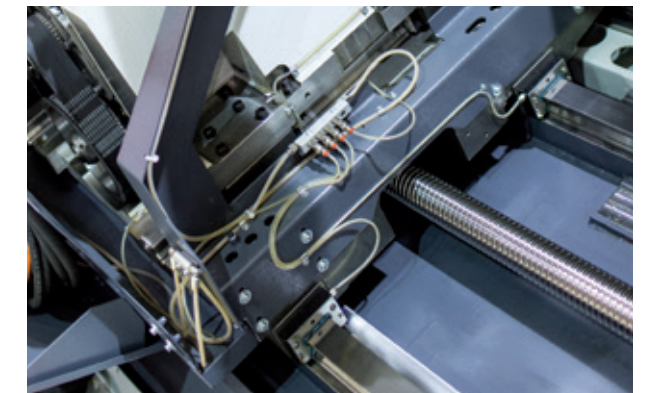

## Y-AXIS

The Y-axis forms a highlight in the MAXXTURN series. She is integrated in the machine structure so that maximum stability based on short overhangs and wide distanced roller guides is guaranteed. Thus, complex machining tasks can be done and workpieces can be completely finished in a single setup.



# NETWORKS ARE CREATED INDIVIDUALLY – OUR SOLUTIONS AS WELL



Staying in touch is important not only among human beings. Persons, machines and the whole production environment must also be connected perfectly and safely in order to ensure efficient procedures during the production process. With EMCONNECT, the machine is optimally equipped for this purpose. The optional EMCONNECT Digital Services offer innovative online services for optimized machine operation. The user has always the control of the machine status. The automatic notification in case of malfunctions or standstill of the machine as well as the extended capabilities for remote maintenance, minimise downtimes.



### Integration into control

EMCONNECT offers several possibilities of operation according to different situations. For quick access, apps may be used simultaneously in the side panel of controlling. In this way, you can always look at your familiar numerical control, the well-known centrepiece of the machine.

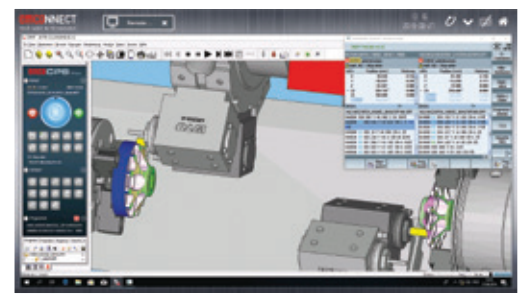

### An innovative concept

These powerful apps may be used independently from the control, while in the background the machine is busy in the production process. With only one click, you can change at any moment between numerical control and EMCONNECT. This is possible with the help of an innovative and ergonomic control panel, equipped with a modern 22" multi-touch display, an industrial PC with associated keyboard and HMI hotkeys.

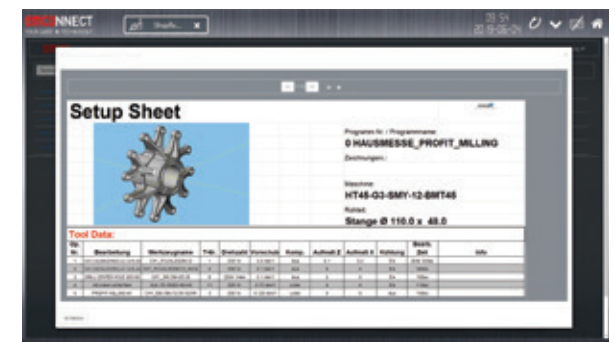

### The control panel as central platform

With EMCONNECT, the control panel of the machine becomes the central platform for the access to all the operative functions. The user gets every type of support from the apps, which directly provide all the necessary applications, data and documents. In this way, EMCONNECT makes an important contribution to a highly efficient processing at the machine.



### Comprehensive connectivity options

With the remote support, the web browser and the remote desktop, there are numerous connectivity options, even beyond the direct production environment. With the help of the integrated remote support, it is easily possible to carry out the remote diagnosis and remote maintenance. The optionally available OPC UA interface enables data exchange with the IT system environment and interaction with other machines for automation at shop floor level.

## EMCONNECT HIGHLIGHTS AND FUNCTIONS

- / Fully connected**  
Connection to all applications via remote control of the office computer and the web browser
- / Structured**  
Clear monitoring of the machine state and the production data
- / Customized**  
Open platform for modular integration of customer-specific applications
- / Compatible**  
Interface for seamless integration into the operating environment
- / User-friendly**  
Intuitive and production-optimized touch operation
- / Future-proof**  
Continuous extensions as well as easy updates and upgrades

### Standard Apps

|                    |                  |
|--------------------|------------------|
|                    |                  |
| Control            | Dashboard        |
|                    |                  |
| Machine Data       | System           |
|                    |                  |
| Remote Desktop     | Web Browser      |
|                    |                  |
| Remote Support     | Settings         |
|                    |                  |
| Cutting Calculator | Calculator       |
|                    |                  |
| Notes              | Service          |
|                    |                  |
| Documents          | EMCO TechSheet   |
|                    |                  |
| GD&T               | File Import      |
|                    |                  |
| Shopfloor Data     | Thread Reference |
|                    |                  |
|                    | Tricalc          |

### Optional

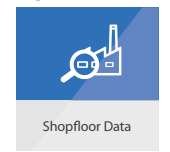

# MACHINE LAYOUT

# WORK AREA

Maxxturn 95  
with VDI40 turret

MAXXTURN 95

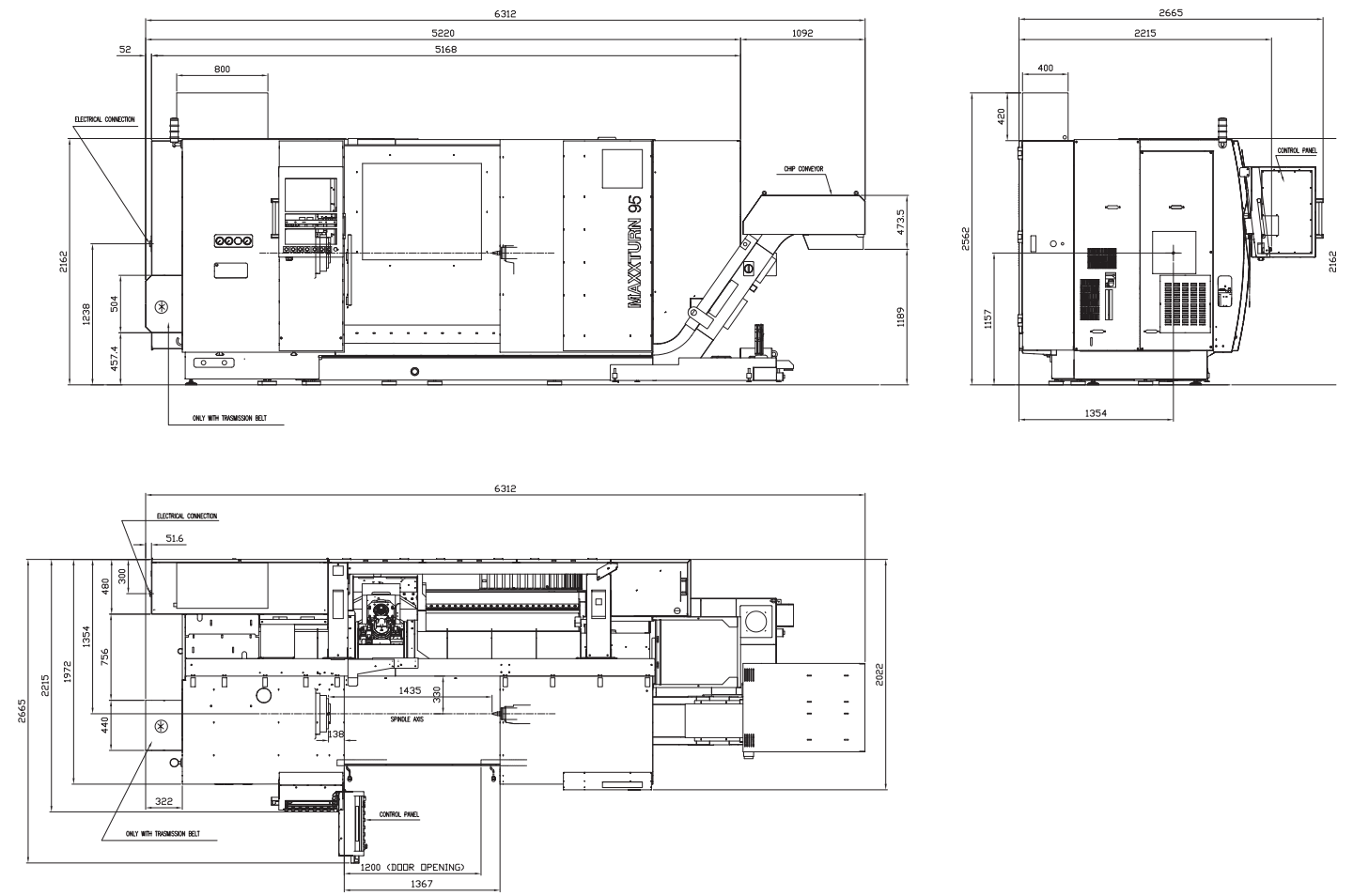

Details in millimeters

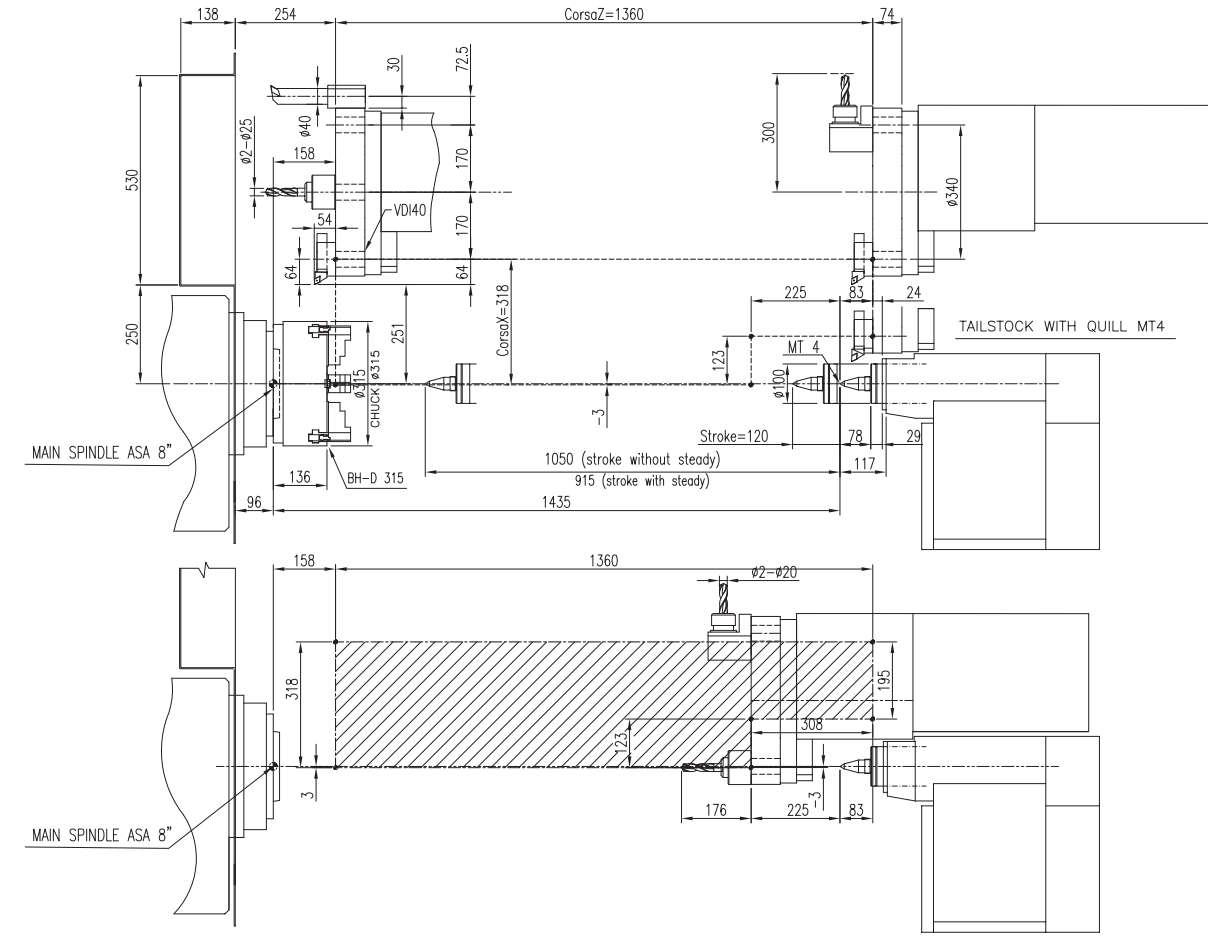

Details in millimeters

# WORK AREA

# WORK AREA

Maxxturn 95  
with VDI40 turret

Maxxturn 95  
with BMT55P turret

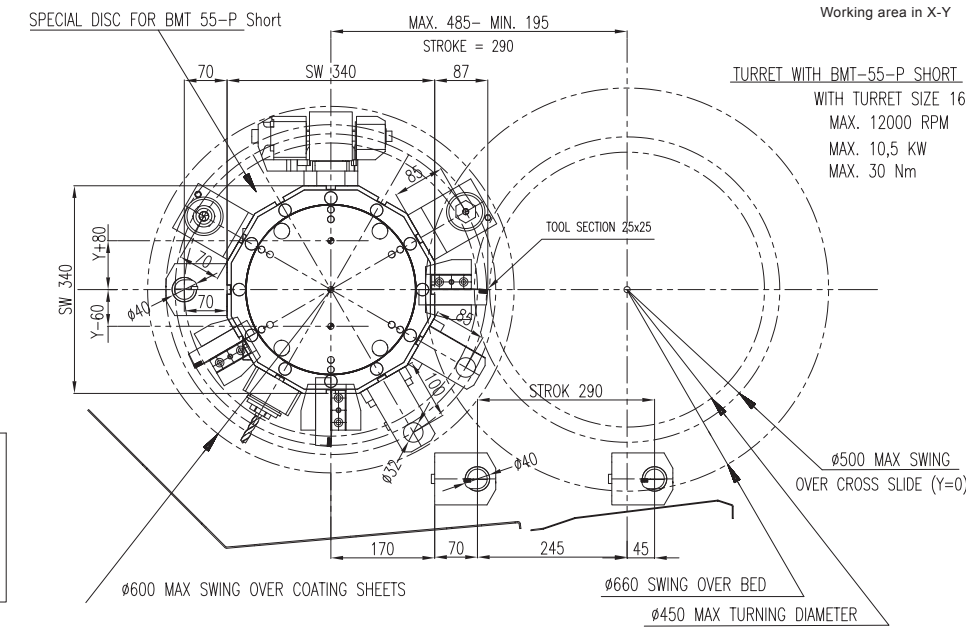
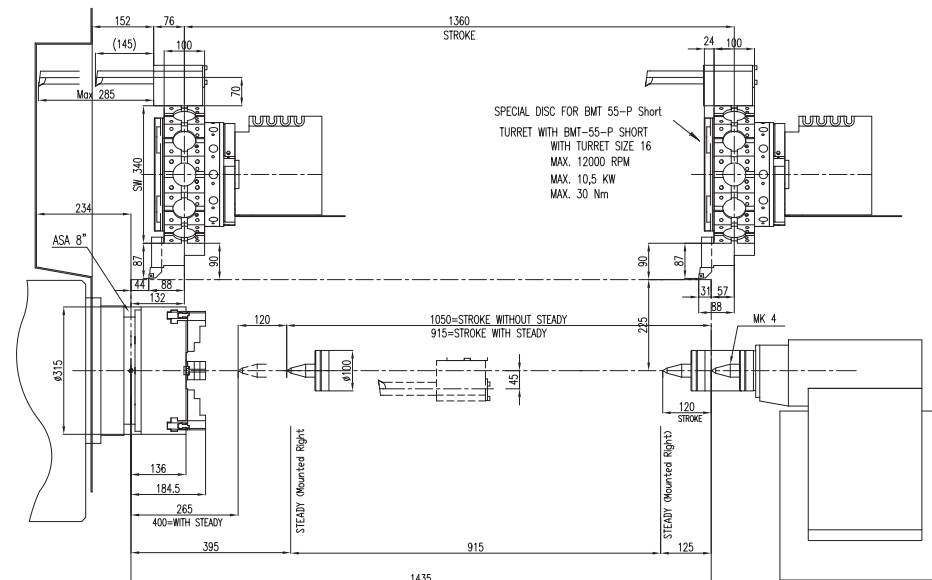
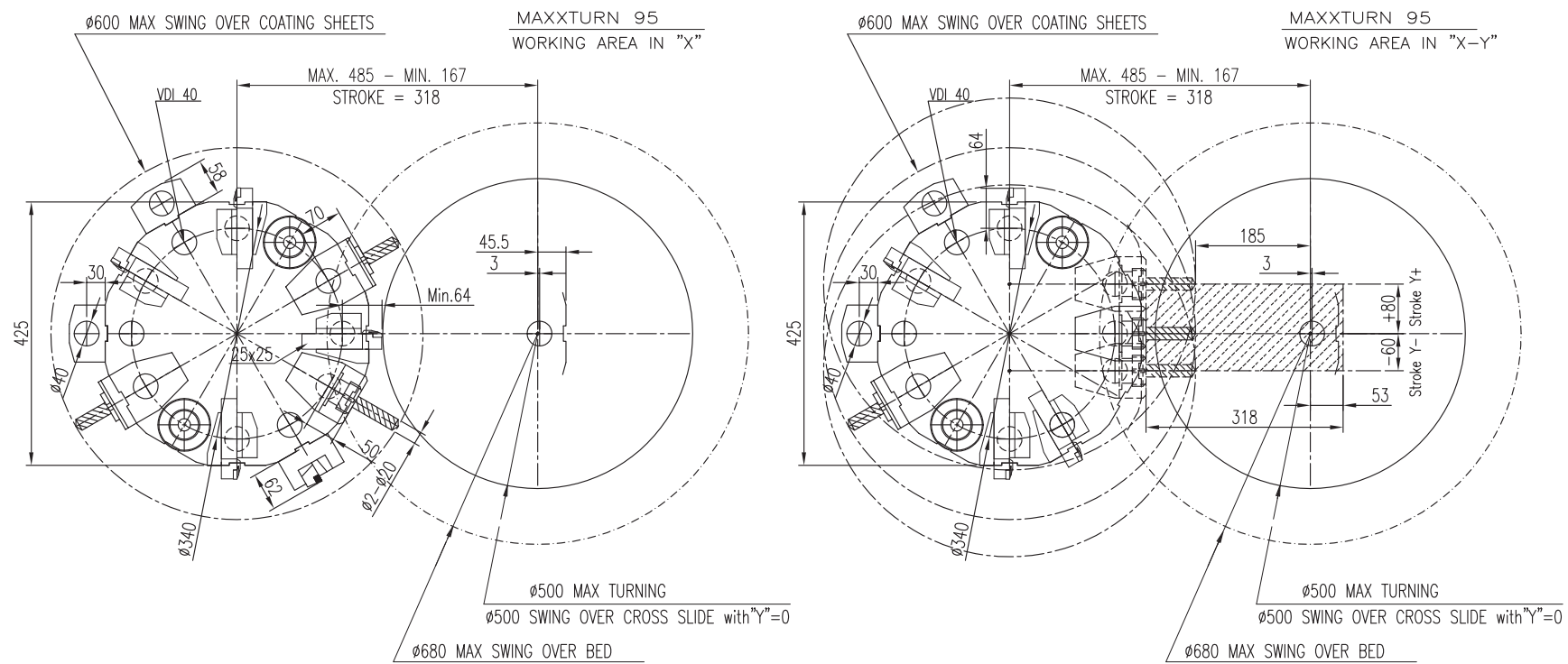

# TECHNICAL DATA

## Work area

|                          |          |
|--------------------------|----------|
| Swing over bed           | Ø 700 mm |
| Swing over cross silde   | Ø 500 mm |
| Distance between centers | 1430 mm  |
| Max. turning diameter    | Ø 500 mm |
| Max. part length         | 1300 mm  |
| Draw tube bore           | 95 mm    |

## Travel

|             |              |
|-------------|--------------|
| Travel in X | 318 mm       |
| Travel in Z | 1360 mm      |
| Travel in Y | -60 / +80 mm |

## Main spindle

|                              |              |
|------------------------------|--------------|
| Spindle nose DIN 55026       | A2-8         |
| Speed range for belt drive   | 0 – 2500 rpm |
| Max. drive performance       | 42 kW        |
| Max. torque on the spindle   | 1040 Nm      |
| Speed range for direct drive | 0 – 3500 rpm |
| Max. drive performance       | 33 kW        |
| Max. torque on the spindle   | 800 Nm       |

## C-axis with direct drive

|                       |          |
|-----------------------|----------|
| Round axis resolution | 0,001°   |
| Rapid motion speed    | 1000 rpm |

## Tailstock with quill

|   |         |
|---|---------|
| Tailstock travel                              | 1050 mm |
| Max. application force                        | 12500 N |
| Max. traverse speed                           | 4 m/min |
| Tool holding shaft (with integrated bearings) | MK 4    |

## Tool turret

|   |                    |
|---|--------------------|
| A number of tool positions                            | 12 + 12            |
| Tool holding shaft in accordance with VDI (DIN 69880) | 40 mm / 25 x 25 mm |
| Tool cross-section for square tools                   | 40 mm              |
| Shank diameter for boring bars                        | 0,4 sec            |

## Driven tools

|                          |              |
|--------------------------|--------------|
| Number of tool positions | 12           |
| Max. speed               | 0 – 4000 rpm |
| Max. torque              | 45 Nm        |
| Max. drive performance   | 8 kW         |

## Tool turret with BMT-interface and direct drive system

|   |                      |
|---|----------------------|
| Number of tool positions                | 12                   |
| Precision tool holder interface         | BMT-55P              |
| Tool cross-section for square tools     | 20 x 20 (25 x 25) mm |
| Shank diameter for boring bars          | 40 mm                |
| Turret indexing time                    | 0,5 sec              |
| Max. speed for driven tools             | 0 – 12000 rpm        |
| Max. torque for driven tools            | 30 Nm                |
| Max. drive performance for driven tools | 10 kW                |

## Feed drive

|  |                    |
|--|--------------------|
| Rapid motion speed X / Z / Y             | 24 / 30 / 12 m/min |
| Feed force in the X axis                 | 9000 N             |
| Feed force in the Z axis                 | 13000 N            |
| Feed force in the Y axis                 | 9000 N             |
| Acceleration time from 0 to rapid motion | 0,2 sec            |

## Coolant system

|                  |            |
|------------------|------------|
| Tank volume      | 350 liters |
| Pump performance | 1,15 kW    |

## Electrical and air connection

|                       |        |
|-----------------------|--------|
| Connection value      | 46 kVA |
| Air pressure required | 6 bar  |

## Dimensions

|                                  |                |
|----------------------------------|----------------|
| Height of centers above floor    | 1155 mm        |
| Machine height                   | 2150 mm        |
| Required space for machine W x D | 5422 x 2249 mm |
| Total weight approx.             | ca. 11000 kg   |



beyond standard /

EMCO GmbH / Salzburger Str. 80 / 5400 Hallein-Taxach / Austria / T +43 6245891-0 / F +43 624586965 / info@emco.at

[www.emco-world.com](http://www.emco-world.com)